

High Spectral Purity Oscillator at 40 GHz: Design Using Air-Dielectric Cavity

Archita Hati, Craig W. Nelson, Bill F. Riddle and David A. Howe
National Institute of Standards and Technology
Boulder, USA
archita@boulder.nist.gov

Abstract— We describe the design of a low-phase modulated (PM) noise 40 GHz oscillator that uses a conventional air-dielectric cavity resonator as a frequency discriminator to clean up the PM noise of a commercial 10 GHz dielectric resonator oscillator (DRO) multiplied by four. The main features of this design incorporate (1) unloaded cavity quality factor (Q) of 30,000, (2) high coupling coefficient, (3) large carrier suppression by use of interferometric signal processing, (4) large operating signal power of approximately 1 Watt (W), and (5) relatively small size.

I. INTRODUCTION

High spectral purity oscillators are required for millimeter wave communication and radar systems operating at Ka- band (26.5 to 40 GHz). Designing high spectrally pure oscillators at these high frequencies is quite challenging due to the frequency limitations of active devices. One approach of generating a millimeter wave reference signal is to simply multiply the frequency of an oscillator operating at lower sub-multiple frequency. However, this technique has its own limitations. The best low frequency oscillators are often bulky and costly. Also, frequency multipliers introduce higher phase-modulated (PM) noise at offset frequencies far from the carrier. When a low-noise oscillator is multiplied up to a higher frequency, its noise increases by $10\log(N^2)$, where N is the multiplication factor. The noise of the frequency-multiplied signal is usually higher than the multiplier noise at offset frequencies close to the carrier, but lower at offset frequencies far from the carrier. Therefore, due to the inherent noise of the multiplier, the low PM noise of an oscillator can not purely be up-converted by simple frequency multiplication.

Some microwave oscillators of lowest noise employ frequency locking to a high-Q resonance cavity to clean up the broadband PM noise [1-5]. The cavity resonator is used primarily as a frequency discriminator. Any improvement of the discriminator sensitivity directly translates to the

improvement in the oscillator PM noise. There are several key aspects of controlling the cavity discriminator sensitivity, and the most important one of these consists of increasing the cavity Q [2, 6]. The other key aspect of controlling the discriminator sensitivity relates to the degree of suppression of the carrier signal reflected from the cavity. The suppression reduces the effective noise temperature of the nonlinear mixer, which acts as the phase detector. The amount of carrier suppression can be increased by making the effective coupling coefficient into the cavity approach its critical value of unity [2] and also by use of interferometric signal processing [4, 5]. Another important aspect of the discriminator sensitivity is that it scales directly as the power of the oscillator signal incident into the cavity [7]. So, by increasing the power of the carrier signal, the discriminator sensitivity can be improved as long as the resonator remains linear, where power does not change frequency.

All of these attributes are contained in an air-dielectric cavity resonator. These design considerations not only work in the development of a cavity-stabilized oscillator (CSO) of high spectral purity at 40 GHz, but have notable advantages when compared to the usual 10 GHz case.

II. COMPACT AIR-DIELECTRIC CAVITY RESONATOR

An important goal of microwave oscillator design is to achieve significant reductions in size, weight, and power (so-called SWaP) without a noise penalty. This paper investigates one strategy of SWaP at state-of-the-art spectral purity. The basic approach that has been used in the past at NIST consists of improving the phase noise of a 10 GHz voltage-controlled oscillator (DRO, yttrium iron garnet (YIG) oscillator, etc.) by use of a high Q, highly linear air-dielectric 10 GHz cavity as a discriminator [7]. Unloaded Q's of 50,000 to 70,000 are attained for TE₀₂₃ or TE₀₂₅ modes, but this moderately high Q results in a fairly large cavity of diameter and height approximately 8 cm. With minimal sacrifice in noise, we can use a significantly smaller 40 GHz highly linear air-dielectric cavity as a discriminator. The air-dielectric cylindrical cavity used in the CSO design is operating at TE₀₁₅ mode, and its inside dimensions are approximately 2 cm diameter and 2 cm

long. It has an unloaded quality factor (Q) of approximately 30,000.

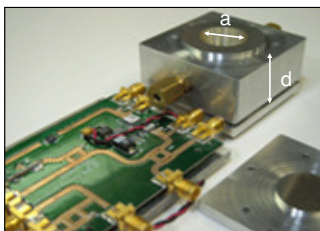

Figure 1. Air-dielectric cylindrical Al cavity resonator at 40 GHz. The diameter (a) and the length (d) of the cavity are approximately 2 cm.

The cavity is made of aluminum (Al) and the inside surface of the cylinder and end plates are silver-plated and highly polished. The cavity used for the CSO design is shown in Fig. 1. The signal is coupled to the magnetic field in and out of the cavity by use of coupling probes (loops) on the end plates with their planes aligned with the radial plane of the cylindrical cavity. The coupling coefficient (β) for the input probe at which carrier suppression occurs is 0.94, and the output probe for obtaining the cleanest 40 GHz is 0.1.

III. DESCRIPTION OF THE CSO

Fig. 2 is the block diagram of the CSO at 40 GHz. It consists of a DRO (dielectric resonator oscillator) at 10 GHz whose free-running PM noise is approximately -112 dBc/Hz at a 10 kHz offset frequency. The output of the DRO is first multiplied by four and amplified to 30 dBm, or 1 W, by use of a power amplifier. The amplified signal is then applied to the input coupling port of the discriminator cavity through a circulator. The reflected signal out of the cavity exits port 'c' of the circulator and is already highly suppressed, because the cavity coupling is nearly critical.

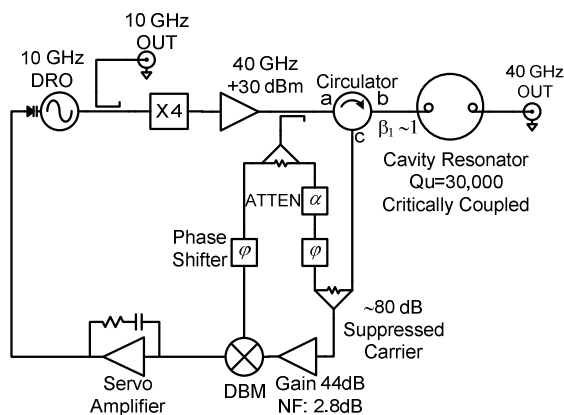

Figure 2. Block diagram of the cavity stabilized oscillator (CSO) at 40 GHz. The 10 GHz DRO is phase-locked to the phase-transfer function of the air-cavity resonance. DBM is double-balanced mixer, ATTEN is attenuator and β_1 is input coupling.

A portion of the input signal adjusted to be of the same amplitude but in opposite phase to the reflected signal, is combined with it to further suppress the carrier (to about -50

dBm). This constitutes the so-called interferometric signal processing. The highly suppressed carrier signal is then amplified by use of a low-noise amplifier (gain = 44 dB, noise figure = 2.8 dB) before being applied to one port of a double balanced mixer (DBM) that acts as a phase detector. Due to the high level of carrier suppression, the amplifier's flicker noise contribution is significantly reduced. The other port of the DBM is a directional coupled portion of the input signal, adjusted to be in phase quadrature with the reflected signal. By having the amplifier before the mixer, the effective noise contribution from the mixer is suppressed by the amplifier gain. The output of the DBM is the error voltage that tracks the frequency fluctuations of the DRO relative to the cavity. This error voltage is applied to the voltage-control tuning input of the DRO through the servo amplifier to stabilize its frequency.

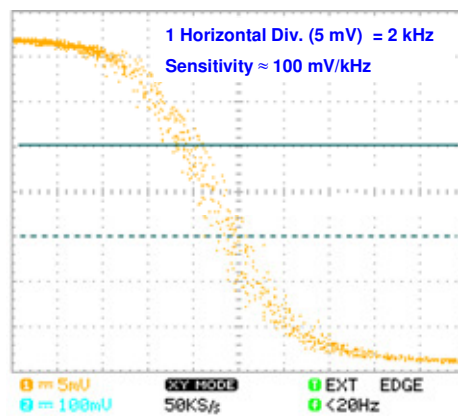

Figure 3. Typical error signal from the double balanced mixer (DBM) in the cavity discriminator of Fig. 2 measured by an oscilloscope. One division along the x and y-axis is equal to 5 mV and 100 mV, respectively. 5 mV along x-axis corresponds to a frequency error of 2 kHz between the (10 GHz \times 4) DRO and the cavity resonance frequency.

Fig. 3 shows a typical error signal at the output of the DBM versus the frequency difference between the resonance frequency of the cavity and the 10 GHz DRO signal multiplied by 4. This slope, which is at the mid point of the resonator discriminator curve, is approximately 100 mV/kHz.

IV. PHASE NOISE RESULTS

Fig. 4 shows the PM noise of a 40 GHz CSO made with an aluminum air-dielectric cavity fabricated with candidate mode, TE₀₁₅ with unloaded Q of about 30,000. The PM noise of the free-running DRO is also shown. There is almost 30 dB improvement in the PM noise. The noise is measured at 10 GHz at the input of the $\times 4$ multiplier due to the unavailability of a 40 GHz reference oscillator, which has either comparable or better PM noise than the CSO. The final results shown in Fig. 4 are normalized to 40 GHz. The drawback of measuring the PM noise at the input of multiplier at 10 GHz is that the $\times 4$ multiplier noise measurement is limited by the multiplier noise. Any corrections of the 40 GHz signal that are lower than the multiplier noise cannot be detected at the 10 GHz output. Fig. 4 shows that above 400 kHz offset frequency, CSO noise is dominated by the $\times 4$ multiplier noise. If the CSO PM noise is measured at the output of the multiplier, we

would expect the noise to be lower above the 400 kHz offset frequency.

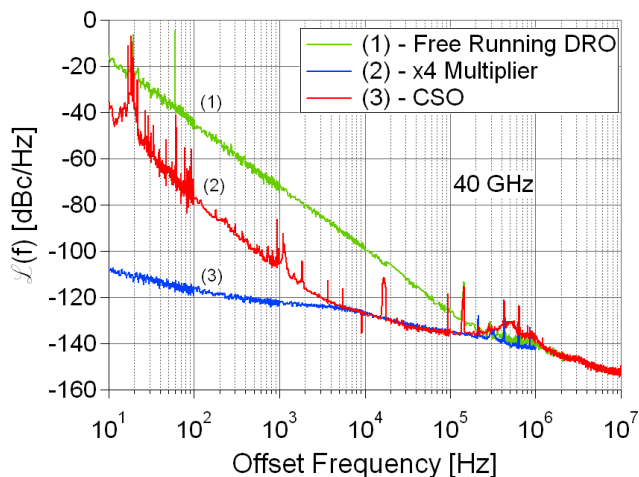

Figure 4. PM noise of a cavity stabilized oscillator (CSO), the results are normalized to 40 GHz. One sees the significant noise reduction of the free-running DRO noise out to beyond 100 kHz offset frequency.

At lower offset frequencies the PM noise is degraded primarily because of the environmental vibration sensitivity of the 40 GHz resonator.

V. CONCLUSION

We report a low PM noise 40 GHz CSO using an air-dielectric cavity resonator as a frequency discriminator. The cavity in TE₀₁₅ mode has unloaded Q of 30,000. The PM noise of the CSO at 10 kHz is -128 dBc/Hz and is expected to be lower if the PM noise measurements are done at 40 GHz instead of at 10 GHz. In the future we plan to

- build a second 40 GHz CSO as a reference for accurate PM noise measurement at 40 GHz.
- use 40 GHz YIG oscillator instead of a 10 GHz DRO and a $\times 4$ multiplier
- control the cavity temperature
- use vibration isolation
- use an ultra-stiff ceramic cavity resonator
- use a whispering-gallery-mode sapphire resonator

REFERENCES

- [1] F. Walls, C. Felton, and T. Martin, "High spectral purity X-band source," *44th Annual Symposium on Frequency Control*, Baltimore, MD, USA, pp. 542-548.
- [2] D. Santiago and G. Dick, "Microwave frequency discriminator with a cooled sapphire resonator for ultra-low phase noise," *Proceedings of the 1992 IEEE Frequency Control Symposium*, Hershey, PA, USA, pp. 176-182.
- [3] D. Santiago and G. Dick, "Closed loop tests of the NASA sapphire phase stabilizer," *1993 IEEE International Frequency Control Symposium*, Salt Lake City, UT, USA, pp. 774-778.
- [4] E. Ivanov, M. Tobar, and R. Woode, "Advanced phase noise suppression technique for next generation of ultra low-noise microwave oscillators," *Proceedings of the 1995 IEEE International Frequency Control Symposium (49th Annual Symposium)*, San Francisco, CA, USA, pp. 314-320.

- [5] E. Ivanov, M. Tobar, and R. Woode, "Applications of interferometric signal processing to phase-noise reduction in microwave oscillators," *IEEE Transactions on Microwave Theory and Techniques*, vol. 46, Oct. 1998, pp. 1537-1545.
- [6] M. Tobar, E. Ivanov, R. Woode, and J. Searls, "Low noise microwave oscillators based on high-Q temperature stabilized sapphire resonators," *Proceedings of IEEE 48th Annual Symposium on Frequency Control*, Boston, MA, USA, pp. 433-440.
- [7] A. Gupta, D. Howe, C. Nelson, A. Hati, F. Walls, and J. Nava, "High spectral purity microwave oscillator: design using conventional air-dielectric cavity," *IEEE Transactions on Ultrasonics, Ferroelectrics and Frequency Control*, vol. 51, 2004, pp. 1225-1231.