

Phase noise suppression in frequency comb generators*

C.W. Nelson, A. Hati, J.F.G. Nava, and D.A. Howe

National Institute of Standards and Technology

325 Broadway

Boulder, Colorado, USA

Email: craig.nelson@boulder.nist.gov

Abstract— We propose an idea to suppress the flicker (1/f) noise in radio frequency (RF) multiplier-based frequency comb generators. Comb generators are often used for frequency multiplication in frequency synthesis. In general, comb generators apply high power to a nonlinear element (NLE) such as a step-recovery diode to generate harmonics. Flicker of phase from the NLE causes significant noise to be projected onto the higher-order harmonics of the input signal. The phase noise of the n -th harmonic increases by n^2 relative to the noise of the input signal; this is also true for the input-referred multiplier phase noise. A system can be constructed that compares the fundamental signal before and after it enters the comb generator. If the phase perturbations between the fundamental and any particular harmonic can be measured in real time, a feedback or feed-forward servo can be implemented to correct the phase noise that is introduced by frequency multiplication. A defective excessively noisy comb generator is used in this experiment to act as the candidate for noise correction. This allows for simplified testing of the proof of principle by measuring the corrected candidate versus a typical comb generator.

Keywords – comb generation, flicker noise, frequency multiplication, phase noise, noise suppression, step recovery diode

I. INTRODUCTION

Frequency synthesis is the generation of new frequencies from a single or ensemble of frequency sources. A frequency synthesis typically uses the combination of frequency multiplication, division, and translation as well as phase-locked loops to achieve the desired new frequencies [1]. Synthesis schemes are often used to create agile tunable new frequencies, or synthesis can also be used to tailor the phase noise of the new output frequencies. The phase noise of the individual components of the synthesis has an important contribution to the final phase noise of the output signal. Frequency multiplication has an important and understood effect on the phase noise of a signal [2]. A multiplied signal's phase noise increases as

$$S'_\varphi(f) = n^2 S_\varphi(f), \quad (1)$$

where $S'_\varphi(f)$ is the double-sideband phase noise of the multiplied signal, $S_\varphi(f)$ is the phase noise of the original signal and n is the multiplication factor. This increase of phase noise for multiplied signals occurs even in the case of an idealized noiseless multiplier. Practical multipliers also

exhibit input-referred, additive and parametric residual noise, which is also multiplied by n^2 and appears at the output [3]. A commonly used multiplier type in RF synthesis is the frequency comb generator (FCG). Two notable types of FCGs are the step recovery diode (SRD) and the nonlinear transmission line (NLTL). In contrast to a simple frequency multiplier, which just provides the n -th desired harmonic, the comb generator provides a set of harmonics ($n = 1, 2, 3, \dots, k$) simultaneously. It is this class of multipliers that will be examined in this work. Since the FCG is typically used for large multiplication factors, its residual noise is of special interest, because it can dominate the noise of multiplied signals [4,5].

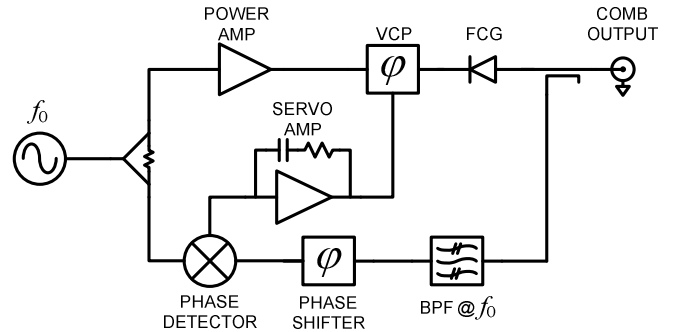

Figure 1 - Block diagram of frequency comb generator noise-suppression scheme. f_0 is the input frequency, VCP is a voltage-controlled phase shifter and BPF is a band-pass filter centered at frequency f_0

II. DESCRIPTION

A method for the suppression of phase noise in frequency comb multipliers is proposed in Figure 1. A typical comb generator is composed of a power amplifier followed by the nonlinear element (NLE) of the FCG, which generates harmonics of the fundamental excitation input frequency. The comb generator is unique in that it also passes the fundamental frequency through the NLE. This fundamental of the comb output is filtered and used to measure the residual phase noise added by the NLE by quadrature detection in a double-balanced mixer. The residual noise of the comb generator, now down-converted to baseband, is used in a closed-loop fashion to pre-distort the input signal to NLE via a voltage controlled phase shifter. This technique is similar to what has been done for feedback noise reduction in amplifiers [6].

* Work of the US government, not subject to copyright.

This correction signal could be also applied in a feed-forward fashion [7], or as a frequency modulation at the tuning port of the input signal. Because the correction of the multiplication occurs at the fundamental base frequency of the comb, correlated noise on all harmonics that can be referred to the input can be corrected simultaneously.

III. MEASUREMENT CONFIGURATION

Figure 2 shows the measurement setup used to verify the proposed noise suppression scheme. A low-noise oven-controlled crystal oscillator (OCXO) at 100 MHz is multiplied to 500 MHz to serve as the input signal to FCG. The measurement setup consists of a candidate FCG that is configured with the noise-correction scheme described in section II. The 20th harmonic of the comb at 10 GHz is filtered and mixed with the 20th harmonic of a second reference comb in a residual measurement. The candidate FCG was chosen to be a defective noisy NLTL type with a 40 dB higher level of noise than the reference SRD-type FCG. This simplified measurements allowing for testing of noise improvements up to 40 dB without requiring the construction of two cancellation circuits, while still testing the proof of principle. Additional isolators and attenuators were included to minimize the detrimental effect of the comb output reflecting back into the FCG. The residual phase noises of the reference and open-loop candidate FCG are shown in Figure 3. A simple proportional-integral (PI) controller was used to apply a closed loop feedback signal to the voltage controlled phase shifter.

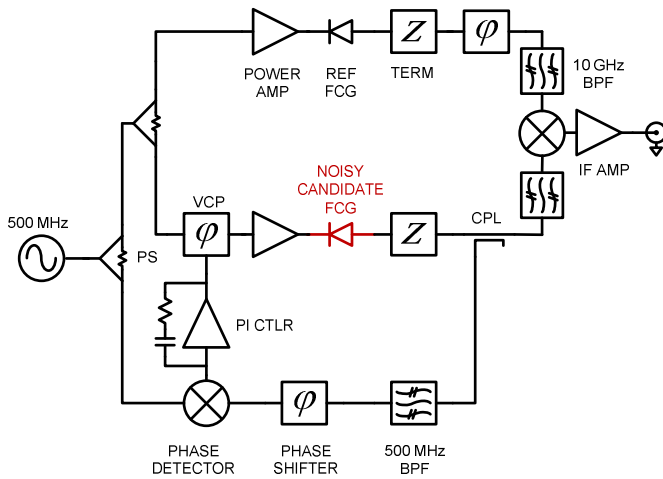

Figure 2 - Block diagram of experimental measurement setup. Items are abbreviated as: Power Splitter (PS), Reference (REF), Voltage Controlled Phase Shifter (VCP), Directional Coupler (CPL), Proportional-Integral Controller (PI CTRL) and FCG attenuator/isolator termination (TERM).

IV. EXPERIMENTAL RESULTS

Residual phase noise results of the noise suppression scheme operating on the noisy candidate FCG are shown in Figure 4. The residual noise of circuit is shown in open loop as well as for two different PI gain values of the control loop. The PI

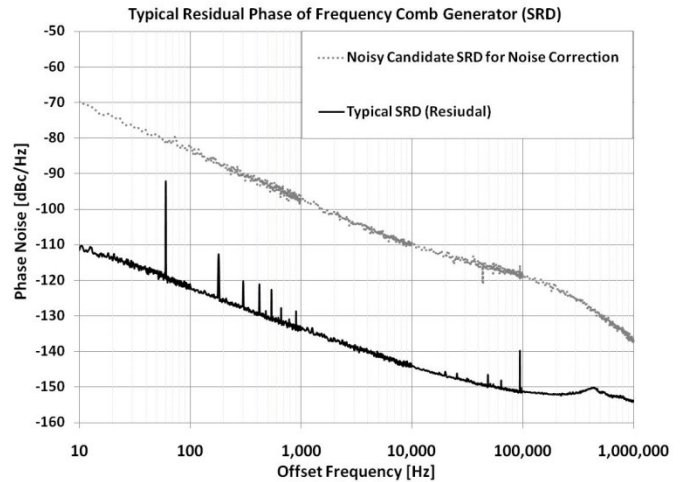

Figure 3 - Phase noise of typical frequency comb generators at 10 GHz.

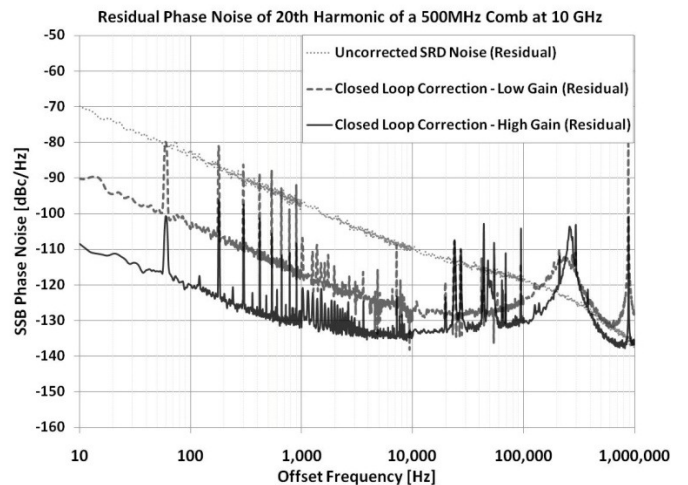

Figure 4 – Residual phase noise of frequency comb generator with and without noise reduction.

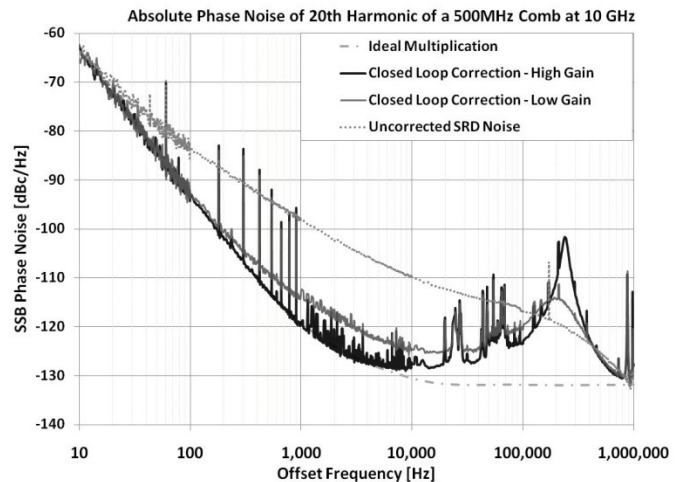

Figure 5 - Absolute phase noise measurements of signal source multiplied with frequency comb generator with and without noise reduction.

controller used switch-selectable time constants and gain controls. No attempt was made to rigorously optimize the control loop. The gain peaking at 300 kHz is due to the limited

frequency response of the PI controller as well as possibly time delay through the NLTL structure of the candidate FCG. The residual phase noise of the corrected FCG shows improvements of nearly 40 dB. Figure 5 also shows the absolute phase noise of the 10 GHz, 20th harmonic of the frequency comb with correction on and off.

V. CONCLUSIONS

A proof of principle was demonstrated for the correction of phase noise in RF frequency comb multiplication. The presence of the fundamental in the comb allows for an *in situ* residual phase noise measurement that can be used for a real-time correction of the multiplied signal. Residual noise improvements of up to 40 dB were demonstrated on a noisy FCG using the 20th harmonic at 10 GHz. In the future we plan to:

- Expand the testing from a noisy comb generator to a state-of-the-art comb generator.
- Optimize the control system for higher-bandwidth operation.
- Test how well the correction works on higher harmonics.

REFERENCES

- [1] V.F. Kroupa, *Frequency Synthesis: Theory, Design & Applications*, John Wiley and Sons, 1973.
- [2] E. Rubiola, *Phase Noise and Frequency Stability in Oscillators*, Cambridge University Press, 2010.
- [3] D. Halford, A. Wainwright, and J. Barnes, "Flicker Noise of Phase in RF Amplifiers and Frequency Multipliers: Characterization, Cause, and Cure," *22nd Annual Symposium on Frequency Control*, 1968, pp. 340-341.
- [4] M. Driscoll and T. Merrell, "Spectral performance of frequency multipliers and dividers," *Proceedings of the 1992 IEEE Frequency Control Symposium*, Hershey, PA, USA, pp. 193-200.
- [5] J. McDade, "Measurement of additive phase noise contributed by the step-recovery diode in a frequency multiplier," *Proceedings of the IEEE*, vol. 54, 1966, pp. 292-294.
- [6] M. Driscoll and R. Weinert, "Spectral performance of sapphire dielectric resonator-controlled oscillators operating in the 80 K to 275 K temperature range," *Proceedings of the 1995 IEEE International Frequency Control Symposium (49th Annual Symposium)*, San Francisco, CA, USA, pp. 401-412.
- [7] R.K. Jurgen, "Feedforward correction: a late-blooming design," *IEEE Spectrum*, vol. 9, 1972, pp. 41-43.